

Venus Flashing Kit

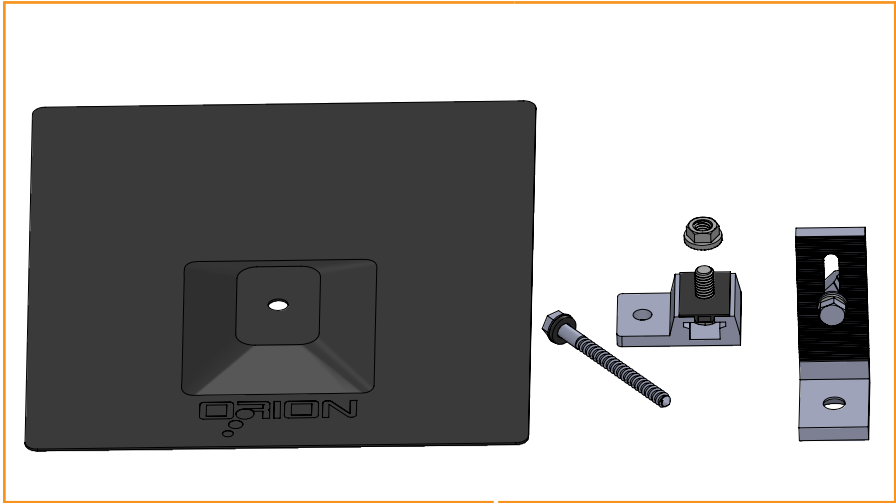

Part #	Finish
GR-FLA-VNS-LFT-MILL	Mill
GR-FLA-VNS-LFT-CLR	Clear
GR-FLA-VNS-LFT-BLK	Black

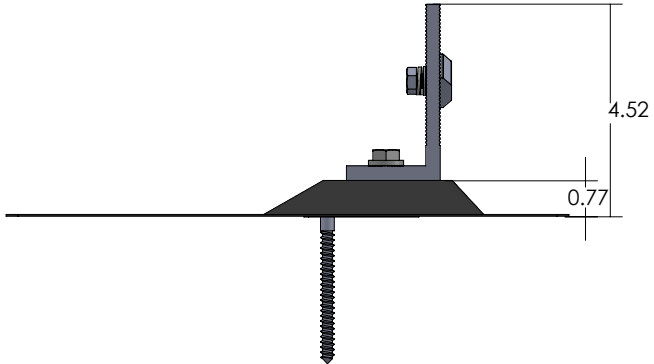
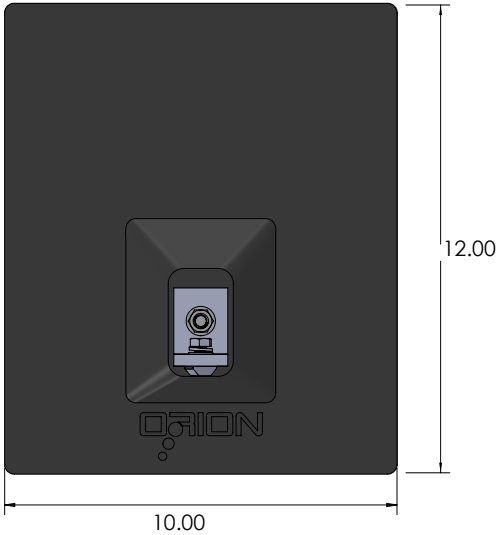

Features:

- Weight: 0.818lb
- Flashing Material: 3003-H14 Aluminum Matte Black over Clear Epoxy
- L-Foot Material: 6063 T6 Aluminum
- Hardware Material: Stainless Steel
- Pre-Assembled
- 3-Part water sealant system



Venus Flashing Kit

Installation Overview

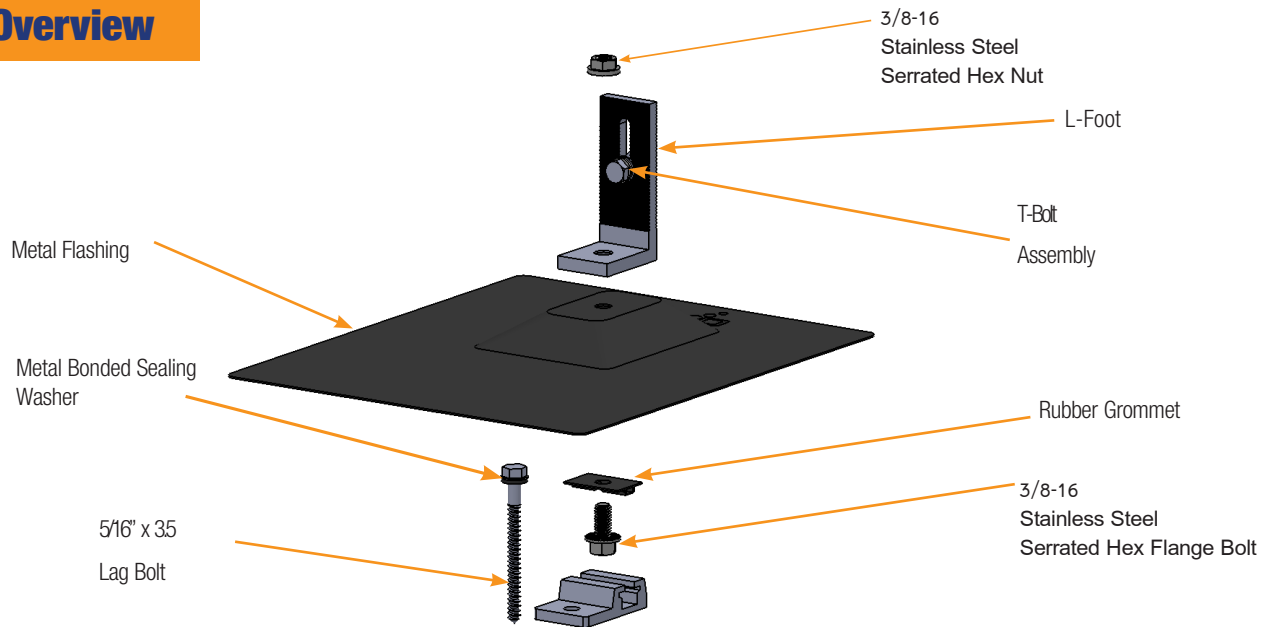

- Locate rafters and chalk horizontal and vertical lines to mark location of penetrations. Drill 1/4" holes and backfill with sealant.
- Use 5/16 x 3.5" lag bolt to secure Venus Shoe Base assembly to the roof.
- Slide long flat edge of flashing under the next shingle up the roof while lining up the hole over the 3/8-16 Bolt on the Venus Shoe Base Assembly.
- Place L Foot assembly over the 3/8-16 Bolt and apply 3/8-16 Nut.
- Tighten 3/8-16 Nut to 230 in-lb torque.

Completed Install

